

# OutTap™ Distribution Unit with Breaker

**UL 891 Listed**

1200A, up to 600VAC  
Series: 3812

## Features



- Solution for temporary remote connection of a facility's permanent generator to a load bank
- 3-Pole Circuit breaker disconnect prevents energizing of cams unless door is closed
- Type 3R heavy gauge galv. steel enclosure with gray powdercoat RAL 7035 (stainless steel & additional colors optional)
- Color-coded cam style female outlets
- Door & deadfront panel for safe circuit breaker operation
- Safety-interlocked lower dead front for safe cable connection
- Hinged access plate secures cable entry compartment when not in use
- Standard side wireway extension for bottom conduit entry (can be omitted for other conduit entry/exit locations)

## Drawing

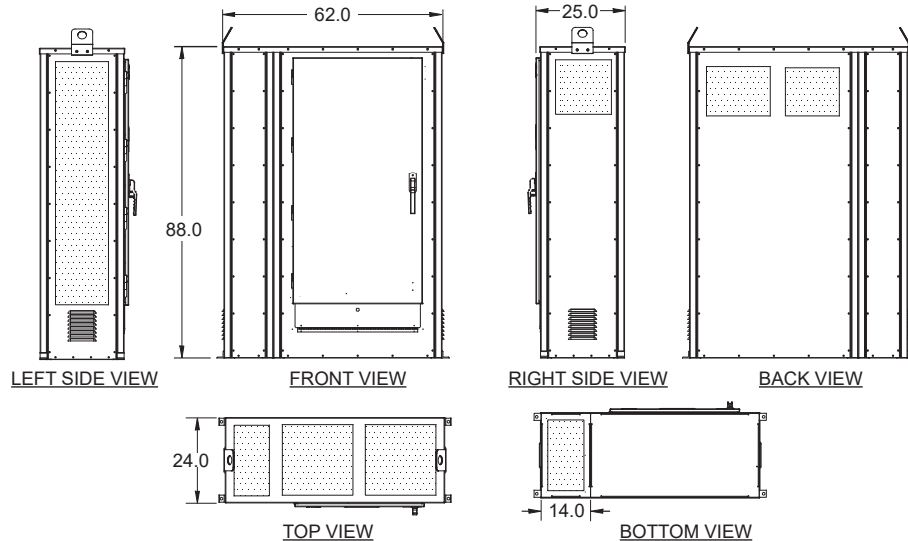

Available incoming conduit entry locations shown shaded

## Approvals

- UL/cUL 891 Listed assembly
- UL 1691 Listed receptacles
- UL 489 Listed / CSA certified molded case circuit breaker

# Specifications

**UL 891 Listed**

OutTap Distribution Unit with Breaker  
Series: 3812

## Ordering Information

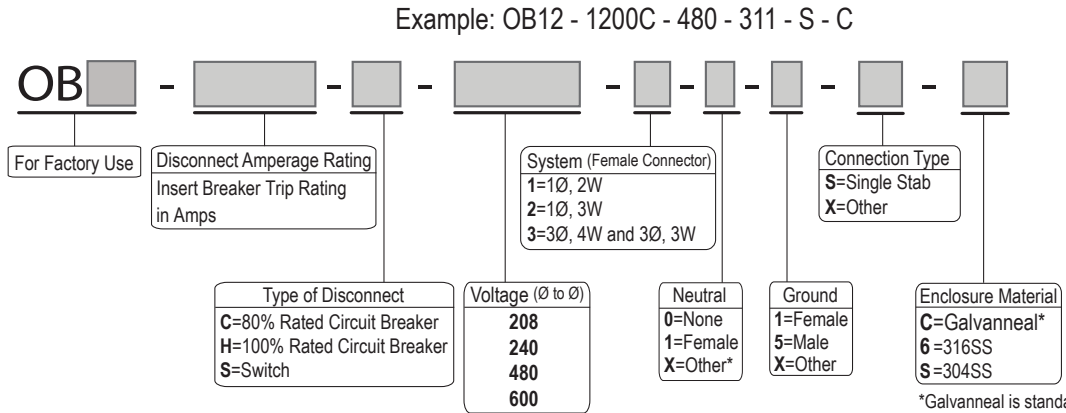

Contact factory for additional options

## Ratings

Short circuit rating (breaker)	50kAIC @ 208VAC & 240VAC, 35kAIC @ 480VAC, 18kAIC @ 600VAC
Withstand rating (switch)	10kA @ 208VAC to 600VAC
Cam-style receptacles	(3) Sets of 400A, 600VAC for phase & neutral (1) 400A, 600VAC for ground
Terminals	Disconnect line terminals: (4) 3/0 - 500kcmil per phase Neutral terminals: (4) 300 - 800kcmil Load terminals: (4) 300 - 800kcmil per phase/neutral Ground lug: (10) #2 - 600kcmil Other options available
Environmental	Type 3R, gasketed (Type 3RX with 304SS or 316SS option)

## Packaging

Approximate product weight	1,400 lbs.
Approximate shipping weight	1,480 lbs.