

2-Gang Wall Mount Assembly

32A 480VAC

(32A 380/440VAC per IEC 60309-1 & -2, CEE 17 3h)

Catalog No: E2-R32-480-30-22SNDPP-SP

Item No: 2214-04ANPPW

Features



- UL Listed 2-gang assembly complete with UL Listed safety-interlocked outlets each containing an integral 30A circuit breaker
- Type 4X enclosure manufactured from 14GA seam-welded stainless steel powder-coated texture grey (RAL7038)
- (2) safety-interlocked ESL 32A outlets #1700-56ANPP furnished with “Power On” and “Power Available” indicator lights. Factory wired to power distribution block (PDB)
- UL Listed circuit breaker rated 22kAIC @ 480VAC provides short circuit & overcurrent protection at each outlet
- Each outlet’s actuator rod allows user to turn on/off and reset tripped breaker
- PDB accepts incoming cable range of (1) 2/0 - #14AWG per phase line side

Drawing

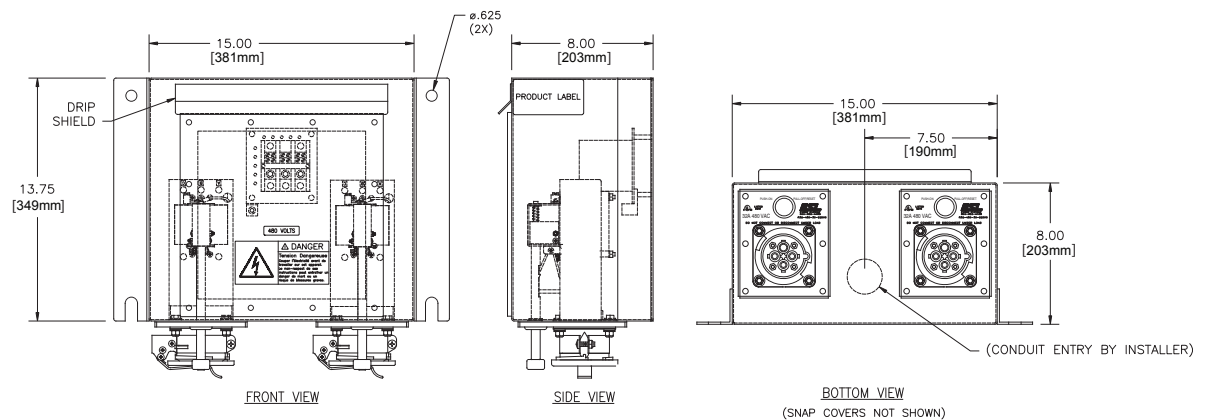

Approvals

- UL Listed modules and assembly
- UL 489 Listed / CSA certified molded case circuit breakers

Specifications

Catalog No: E2-R32-480-30-22SNDPP-SP

Item No: 2214-04ANPPW

Ratings

2-Gang assembly	60A 480VAC (440/480VAC 50/60hz) 3 phase 3 wire + ground, 22kAIC RMS symmetrical amps
Receptacles	32A 480VAC (380/440VAC 50/60 Hz) per IEC 60309-1 & -2, CEE 17 3h
Circuit breakers	30A trip, 22,000AIC @ 480VAC, other trip and AIC ratings available - contact factory
Environmental	Type 4X/IP66
PDB terminals	Line side terminal accepts (1) #14 - 2/0 per phase Ground terminal accepts (1) #6 - 2/0
Indicator lights	480V neon lamps, red lens "on" & amber lens "avail", 1/3 W, 25,000 hour rated

Materials

Stainless steel	Enclosure, access cover, outlet frames, on/off rods, interlock mechanisms, contact terminal screws & springs, snap covers and all fasteners
Aluminum	PDB Lugs
Nickel plated brass	Contact sleeves
Rynite®	Receptacle insert
Polyamide	Receptacle housing
Buna-N (Nitrile/NBR)	O-rings, gaskets, cover seals

Approximate Weight

Approx. weight	47 lbs.
Approx. shipping weight	52 lbs.

Replacement Parts

Description	Item No.	Description	Item No.
Safety-interlocked power outlet	1700-56ANPP	Circuit breaker	4020-01
Stainless steel snap cover assembly	1500-01	Ground sleeve kit	4016-03
Receptacle insert contact sleeve assembly	4010-75	Phase sleeve Kit	4015-01