

Safety-interlocked Power Outlet

32A 480VAC

Catalog No: R32-480-30-65SNQPP-SP

Item No: 1706-59ANPP

Features

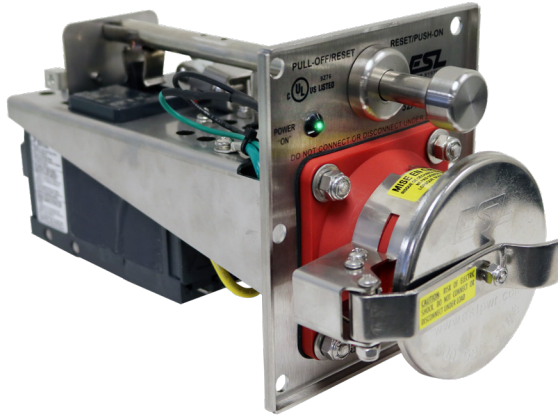

- UL Listed safety-interlocked power outlet containing an integral 30A circuit breaker
- Actuator rod allows user to turn on/off and reset tripped breaker
- UL Listed circuit breaker rated 65kAIC @ 480VAC provides short circuit & over current protection
- “Power On” green LED indicator light (shown as energized). “Power Available” blue LED indicator light
- 2-piece receptacle with polyamide receptacle housing and high temp rynite® insert
- Spring-loaded snap cover protects receptacle when not in use
- Interlocked replacement outlet for use in ESL single gang or multi gang assemblies to power ISO reefer containers

Drawing

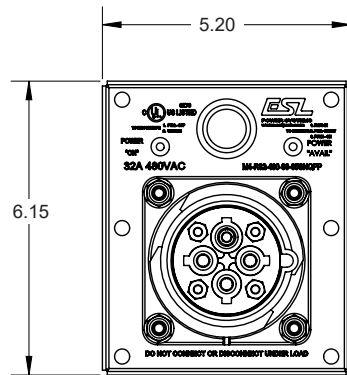

FRONT VIEW

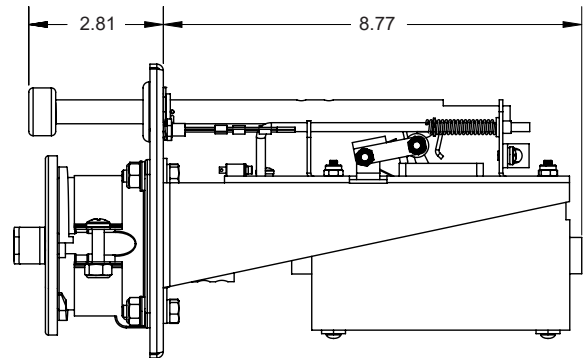

SIDE VIEW

Approvals

- UL/cUL Listed outlet
- UL 489 Listed / CSA certified molded case circuit breaker

Specifications

Catalog No: R32-480-30-65SNQPP-SP

Item No: 1706-59ANPP

Ratings

| | |
|-----------------|--|
| Receptacle | 32A 480VAC (380/440VAC 50/60 Hz) 3h per IEC 60309-1 & -2 |
| Circuit breaker | 3P molded case, 30A trip / 65,000AIC @ 480VAC, other trip and AIC ratings available - contact factory |
| Terminals | Installer wires direct to circuit breaker: (3) phase & (1) ground pressure type screw terminals, Phases: #14 AWG - 2/0 (2.5 - 70mm ²) wire range, Ground: #14 - #6 AWG (2.5-16mm ²) wire range |
| Environmental | Type 4X when housed in ESL single gang or multi gang assembly |

Materials

| | |
|----------------------|--|
| Stainless steel | Frame, faceplate, on/off rod, rod seal, snap cover, interlock mechanism, contact terminal screws & spring, and all fasteners |
| Nickel plated brass | Contact sleeves |
| Rynite® | Receptacle insert |
| Polyamide | Receptacle housing, screw cover (optional) |
| Neoprene (CR) | Gaskets, cover seals |
| Buna-N (Nitrile/NBR) | O-rings |

Packaging

| | |
|---------------------|------------------|
| Product weight | 7 lbs. |
| Shipping weight | 8 lbs. |
| Shipping dimensions | 16in x 8in x 8in |

Replacement Parts

| Description | Item No. | Description | Item No. |
|---|----------|-----------------------------|------------|
| Stainless steel snap cover assembly | 1500-01 | Ground sleeve kit | 4016-03 |
| Receptacle complete housing with insert, contact sleeve & ground assembly | 4010-75A | Phase sleeve kit (set of 3) | 4015-01 |
| Insert, contact sleeve & ground assembly | 4010-76A | Pilot light kit "Green" | 4090-35GNH |
| Circuit breaker kit | 4020-110 | Pilot light kit "Blue" | 4090-35BLH |